

## Product Data Sheet

# AHRS-M2

## Micro AHRS/IMU with AdaptCal™



### Description

The AHRS-M2 is a next generation Attitude Heading Reference System (AHRS) that delivers industry leading static heading accuracy of 0.2° RMS. The AHRS-M2 is a fully temperature compensated, micro-sized, light weight, low power AHRS product with a revolutionary built-in adaptive-calibration mode. It utilizes a proprietary calibration algorithm that provides continuous, adaptive calibration without the need to perform a traditional and complex “12-point” calibration. Instead, the AHRS-M2 learns on the fly, using the natural motion of the application platform to continuously calibrate the platform’s magnetic properties – eliminating hard and soft iron distortions. Ideal for SWaP-C improvements, the system weighs 12.3 grams in a very small form factor. Leveraging market-leading, on-board tri-axial magnetometers and MEMS accelerometers and gyroscopes, the AHRS-M2 delivers temperature compensation, lower heading drift, and superior system performance even in the presence of platform vibration. Sparton’s proprietary state-of-the-art AdaptNav™ sensor fusion algorithms allow the system to provide accurate attitude and heading outputs, including full 360° tilt compensation even when subject to highly dynamic operating environments and transient magnetic interference. The AHRS-M2 also includes Sparton’s NorthTek™ on-board programming environment, making it the world’s only micro-sized, programmable, and configurable AHRS – providing users virtually limitless product customization and integration flexibility.

### Features

- AdaptCal™ provides continuous 3D adaptive in-field calibration with hard and soft magnetic interference compensation
- Integrated AdaptNav™ provides real-time noise characterization and active gyro drift compensation for superior heading, pitch, and roll performance in electrically and mechanically noisy environments
- Static Heading Accuracy, 0.2° RMS
- Small form factor, weighs 12.3g
- Very low power consumption, 60 mW, and Sleep Mode functionality, 16 mW
- Powerful user programmable sensor customization apps via NorthTek™ Forth interpreter
- High resolution, low noise magnetometers
- Advanced sensing technology (tri-axial magnetometers and MEMS accelerometers and gyroscopes)
- Magnetic and True North heading, pitch, and roll measurement
- Full 360° rollover capability using quaternions or rotation matrix
- “Figure of Merit” real time heading error indicator
- In-field calibration point selection and distribution indicator
- Quality of in-field calibration indicator
- Centripetal acceleration correction
- Supports multiple communication protocols

### Typical Applications

- Hand-held and mounted optical targeting systems
- Pan and tilt
- 3-D geospatial surveying
- Antenna positioning
- Towed acoustic arrays/streamers
- Precision unmanned vehicle navigation
- Platform stabilization and orientation
- Accurate attitude, position, and orientation sensing
- Other platforms with motors/electrical noise, and mechanical vibration

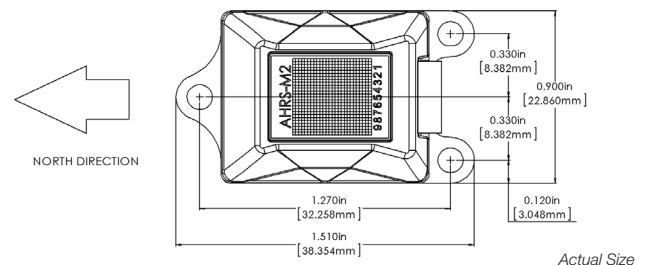
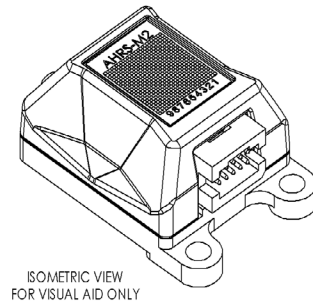

## Specifications

Dynamic Heading Accuracy	1.0° RMS <sup>1</sup>
Static Heading Accuracy	0.2° RMS (<1.0° RMS from -40° to +70° C) <sup>2</sup>
Dynamic Pitch/Roll Accuracy	1.0° RMS <sup>1</sup>
Static Pitch/Roll Accuracy	0.2° RMS
Pitch/Roll Repeatability	0.1° RMS
Pitch/Roll Range	± 90°, ± 180°
Accelerometer Range	± 4g (± 1g) <sup>3</sup>
Accelerometer Noise Density	250 µg/√Hz
Accelerometer Bias Stability	0.07441 mg
Accelerometer Velocity Random Walk (VRW)	0.09123 (m/s)/√Hz
Gyro Dynamic Range	± 500°/sec (± 300°/sec) <sup>4</sup>
Gyro Noise Density (RMS)	0.04°/sec/√Hz
Gyro Bias Stability	6.415°/Hr
Gyro Angular Random Walk (ARW)	0.2546°/Hr
Magnetic Range	±1.2 Gauss (±900 mGauss) <sup>4</sup>
Maximum Magnetic Inclination (Dip)	± 80° <sup>5</sup>
Update Rate	10 or 100 Hz
Baud Rate	1.2, 2.4, 4.8, 9.6, 19.2, 38.4, 57.6, 115.2 kbaud
Dimensions L x W x H	38.4 x 22.9 x 9.1 mm (1.51 x 0.90 x 0.36 inches)
Mass	12.3g
Encapsulated or Enclosure	Yes
Operating and Storage Temperature	-40° to +85° C
Humidity Resistance	95%, 70° C, 24 hrs Meets MIL-STD-202G – Method 103A, Test Condition A
Shock Resistance	5000g, 1ms Pulse, Half-Sine Wave
Vibration Resistance	.02 dB Power Spectral Density, 5.35 G RMS Meets MIL-STD-202G – Method 214A, Test Condition I/C
Power Supply Input (Unregulated Voltage)	+4 to +10V DC
Input Power, Operating Mode (Typical @ 4V)	60 mW
Input Power, Sleep Mode (Typical @ 4v)	16 mW
3.3V Logic UART Interface	Yes
3D and Automatic In-Field Calibration	Yes
Able To Maintain Function When Inverted	Yes
Quaternion/Rotation Matrix Output	Yes
True North Heading Output	Yes
NorthTek™ User Programmable Customization	Yes
Includes World Magnetic Model	Yes
RoHS Compliant	Yes
Fully Temperature Compensated	Yes

Pin #	Pin Name	I/O	Function
P1	GND	0	System Ground
P2	GPIO1	I/O	RESERVED
P3	USER_TXD	0	3.3V logic TXD output from User Com Port
P4	GPIO2	I/O	RESERVED
P5	USER_RXD	I	3.3V logic RXD input to User Com Port
P6	#RESET	I	3.3V logic, active-low reset input (the pin has a weak pull-up)
P7	V+	I	+4 to +10 DC power supply input
P8	UART1_TXD	0	RESERVED
P9	#EINT0	I	3.3V logic, active-low interrupt input (the pin has a weak pull-up) Used for programming purposes
P10	UART1_RXD	I	RESERVED

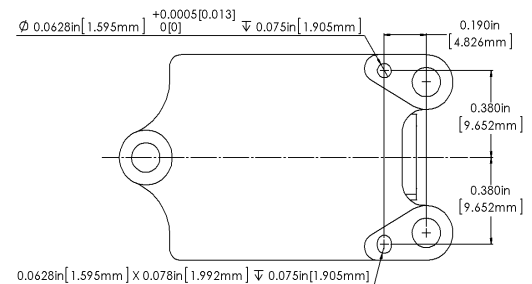
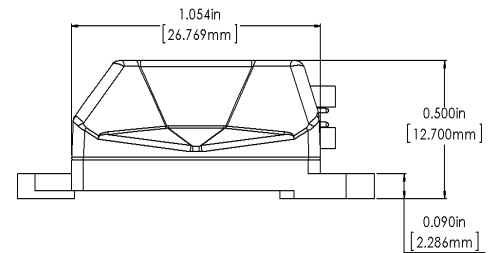
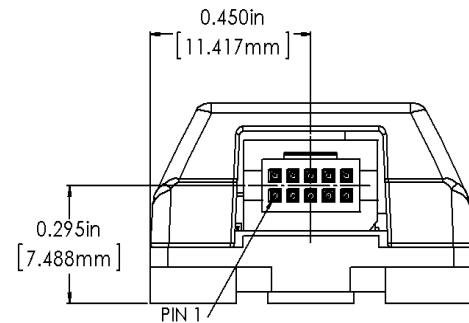

<sup>1</sup> Dynamic heading accuracy derived from Scorsby table set for 7 RPM, 30° of inclination.

<sup>2</sup> Performance data applies under the following conditions unless otherwise specified: 23°C, 0° Pitch/Roll, 300mGauss Horizontal and 0mGauss Vertical Magnetic Field.

<sup>3</sup> Note selection of the high range mode for the accelerometers results in decreased sensitivity, but also offers increased dynamic range. Consequently, optimal mode selection is dependent upon the intended application and associated linear accelerations present.

<sup>4</sup> Specifications in parentheses represent current limits of calibration methodology.

<sup>5</sup> Performance at maximum dip angle will be degraded.

Specifications subject to change without notice.

For more information and detailed specifications scan QR code. For support, please e-mail: [productsupport@sparton.com](mailto:productsupport@sparton.com)

