

NOTICE TO PERSONS RECEIVING THIS DOCUMENT: THIS DOCUMENT IS THE EXCLUSIVE PROPERTY OF AYDIN DISPLAYS, INC. IT CONTAINS PROPRIETARY AND CONFIDENTIAL INFORMATION OF THE COMPANY, AND IS DELIVERED ON THE EXPRESS CONDITION THAT IT IS NOT TO BE DISCLOSED OR REPRODUCED IN WHOLE OR IN PART, NOR USED FOR MANUFACTURE BY ANYONE OTHER THAN AYDIN DISPLAYS, INC.; AND THAT NO RIGHT IS GRANTED TO DISCLOSE OR SO USE ANY INFORMATION CONTAINED IN THIS DOCUMENT

ZONE		LTR		REVISION	DATE	APPROVED
				DESCRIPTION		
	0			INITIAL	6/14/12	EP
	1			UPDATED TO REFLECT VIDEO CONTROLLER CHANGE & ADDITION OF GND STUD, NOTE 2 : 10.5 (AS TESTED) WAS 11.2 (EST), ADDED NOTE 4 FLW 10/31/13	-	EP
	-			RELEASED (SAME AS REV 1)		

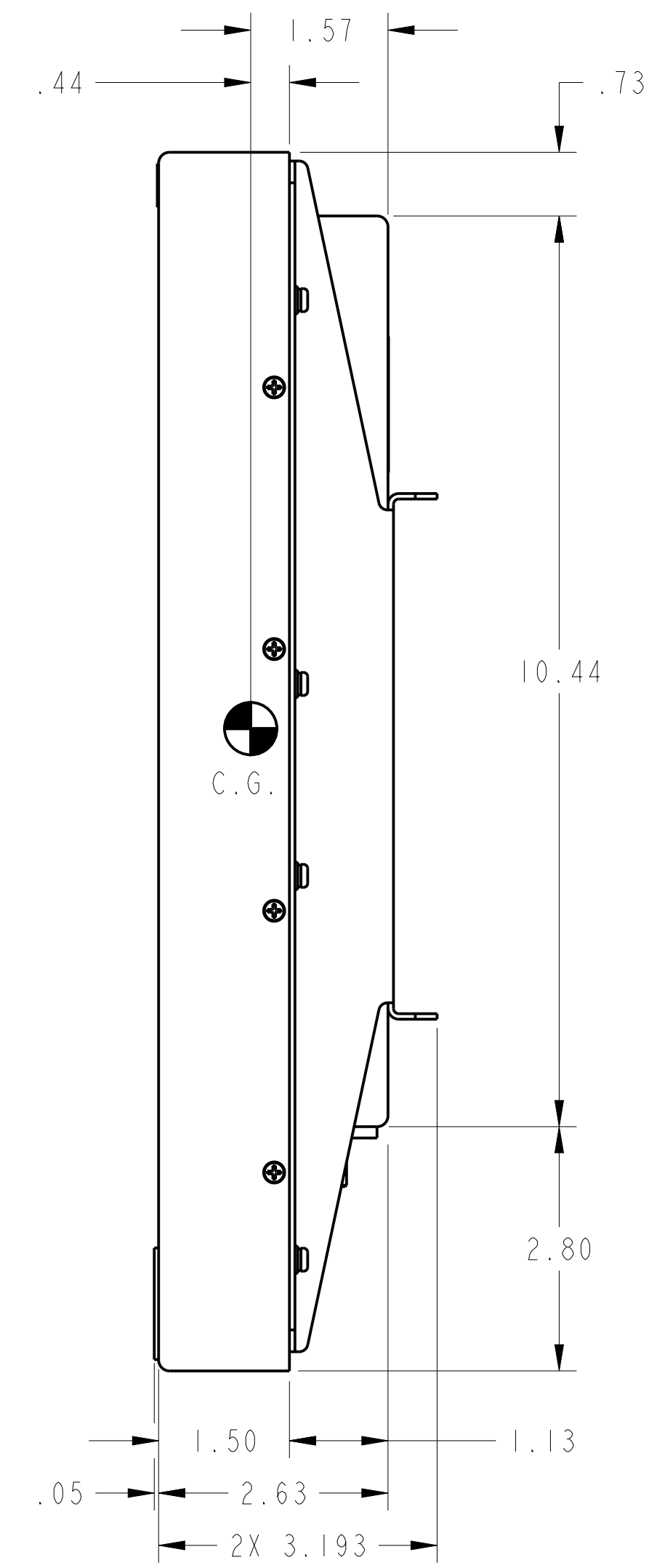
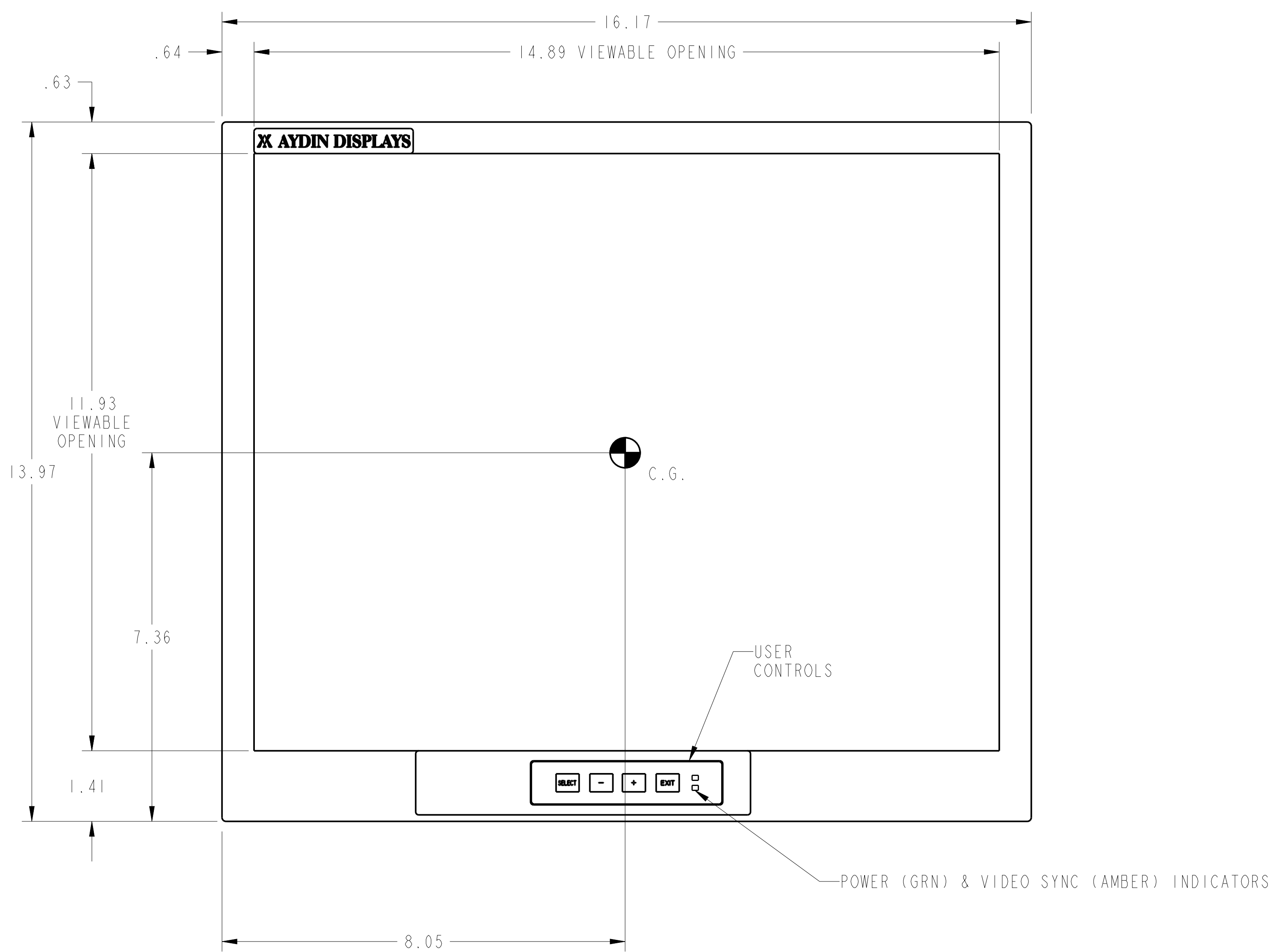
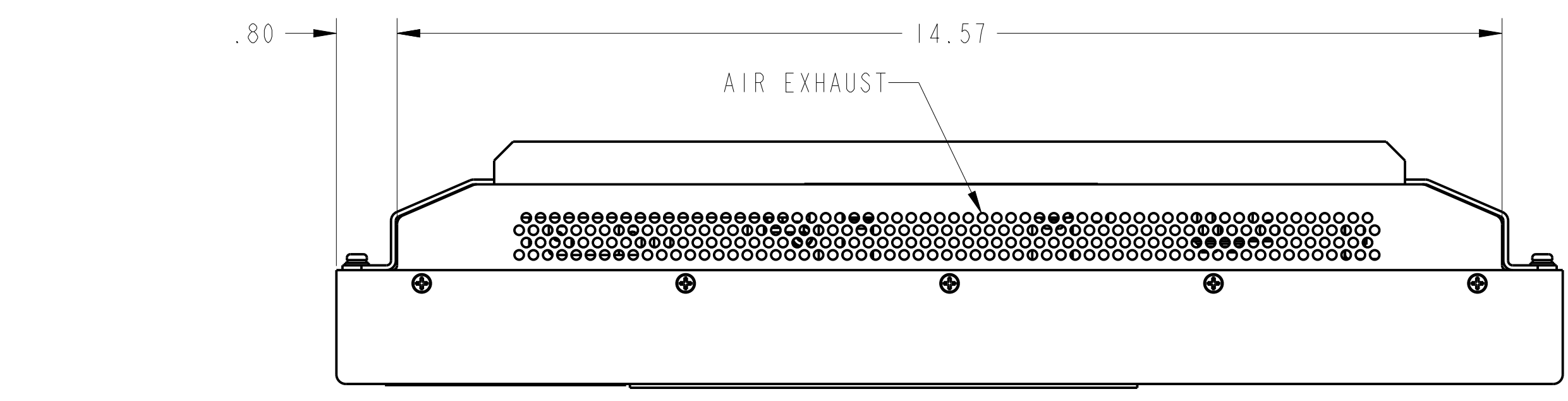

FRONT VIEW

- NOTES:
1. ALL DIMENSIONS ARE NOMINAL AND FOR REFERENCE ONLY UNLESS OTHERWISE SPECIFIED.
  2. WEIGHT: 10.5 LBS (AS TESTED) (⊕ DENOTES CENTER OF GRAVITY, C.G.).
  3. AYDIN P/N IS 356-7067-501.
  4. SHOCK QUALIFICATION NOTE: REFERENCE NSWCCD CODE 669 MEMO, SERIAL 669/132, DATED OCT 7, 2013. ANY CHANGES TO THIS DRAWING OR LOWER TIER DRAWING REQUIRES NAVY REVIEW AND APPROVAL TO MAINTAIN SHOCK QUALIFICATION.

CAD DATA MANAGEMENT

353-7275	ASM	
353-7275	DRW	
353-7275_REV_-	PDF	

DRAWN	F WADLINGER	01-NOV-11
CHECKED	E PELLICCIOTTI	
DRAFTING	N/A	
ENGINEER	E PELLICCIOTTI	
APPROVED MFG	N/A	
APPROVED QA	N/A	
MODEL FILENAME	353-7275	

<b>AYDIN DISPLAYS INC</b>			
TITLE: <b>OUTLINE DRAWING, MODEL 4419A1</b>			
SIZE	CAGE NUMBER	DRAWING NUMBER	REV
<b>D</b>	<b>INSE4</b>	<b>353-7275</b>	<b>-</b>
SCALE: 0.625			SHT 1 OF 2 SHTS

UNLESS OTHERWISE SPECIFIED DIMENSIONS ARE IN INCHES	
NEXT ASSY	USED ON
APPLICATION	

PRO-E GENERATED

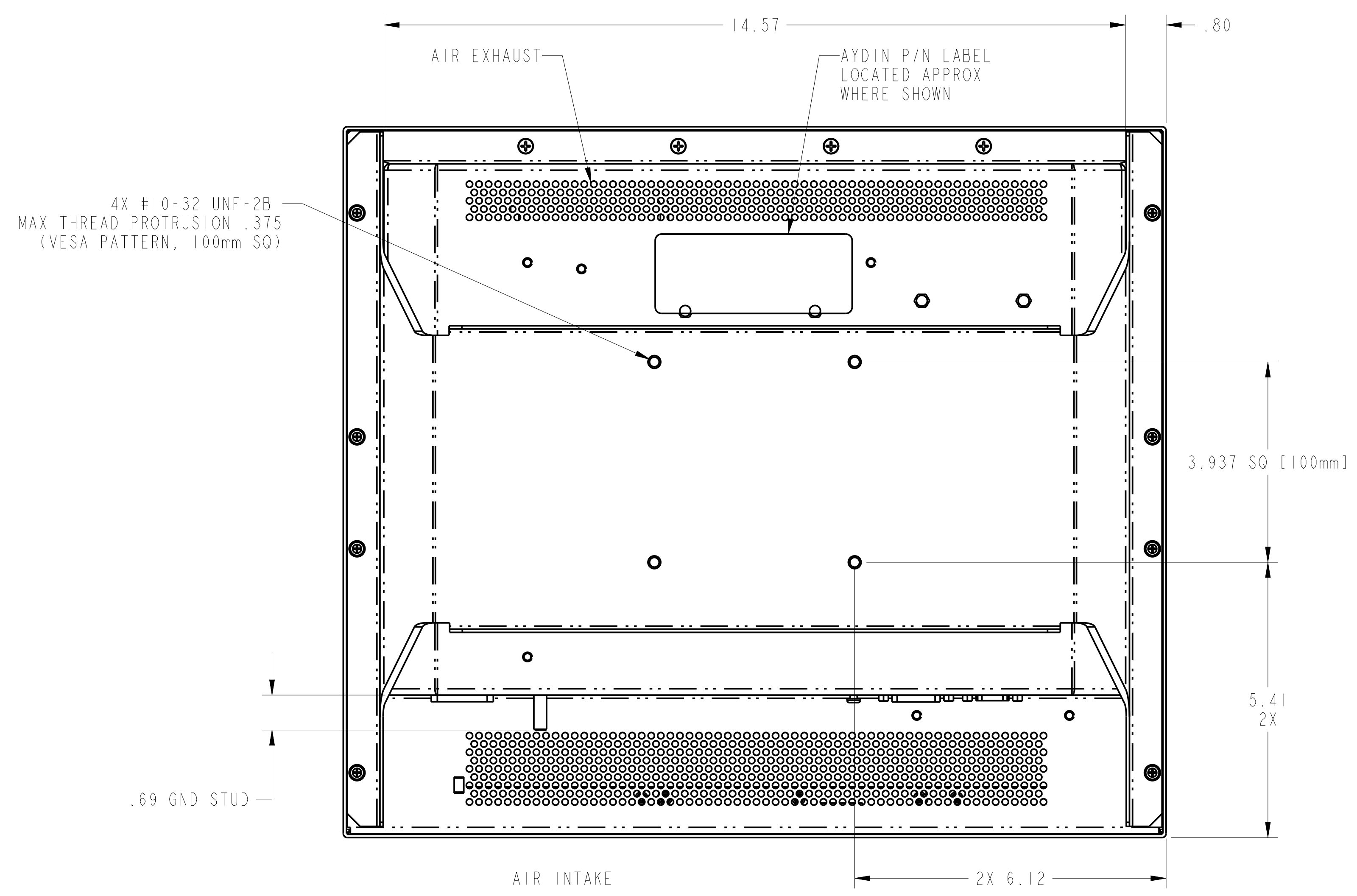

REAR VIEW

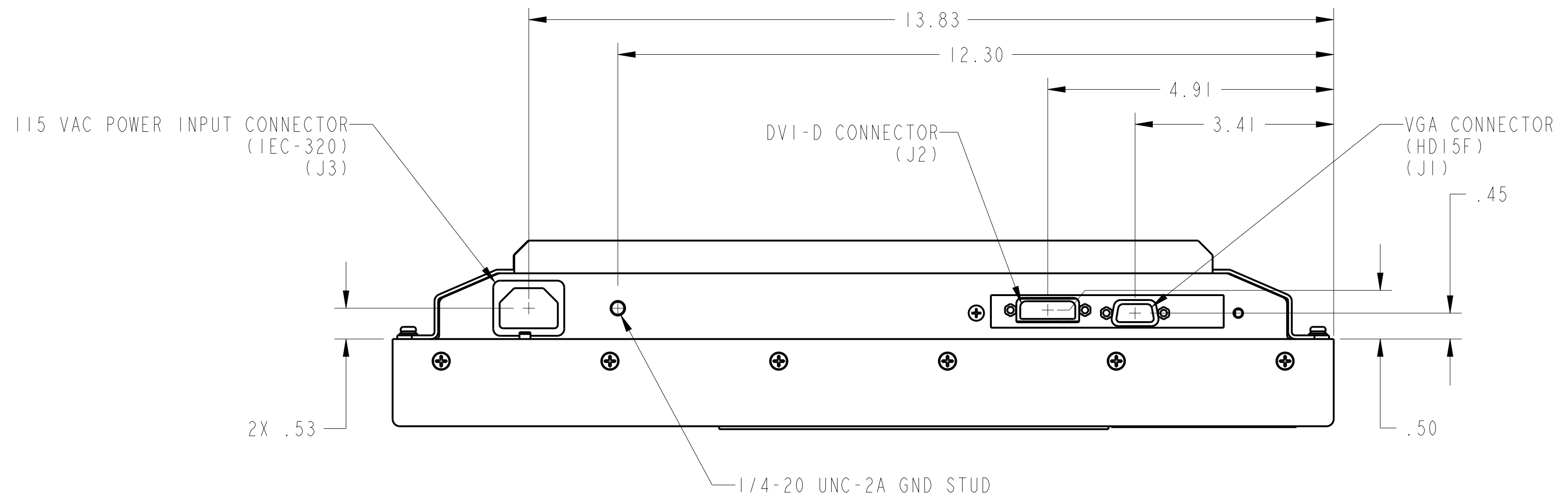
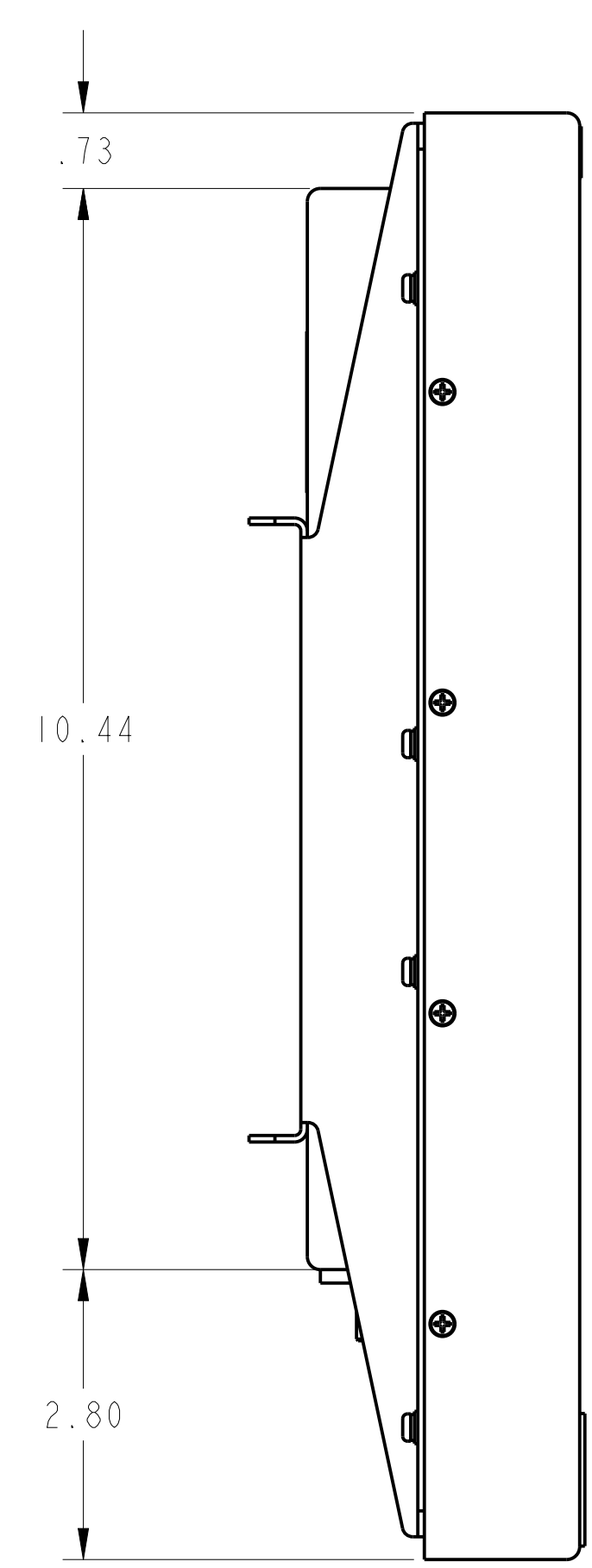

NOTICE TO PERSONS RECEIVING THIS DOCUMENT: THIS DOCUMENT IS THE EXCLUSIVE PROPERTY OF AYDIN DISPLAYS, INC., IT CONTAINS PROPRIETARY AND CONFIDENTIAL INFORMATION OF THE COMPANY, AND IS DELIVERED ON THE EXPRESS CONDITION THAT IT IS NOT TO BE DISCLOSED OR REPRODUCED IN WHOLE OR IN PART, NOR USED FOR MANUFACTURE BY ANYONE OTHER THAN THE AYDIN DISPLAYS, INC.; AND THAT NO RIGHT IS GRANTED TO DISCLOSE OR SO USE ANY INFORMATION CONTAINED IN THIS DOCUMENT

TITLE: **OUTLINE DRAWING, MODEL 4419A1**

SIZE	CAGE NUMBER	353-7275	REV
D	INSE4		-
SCALE: 0.625		SHT 2 OF 2 SHTS	
DRAWN: F WADLINGER		MODEL FILENAME: 353-7275	